

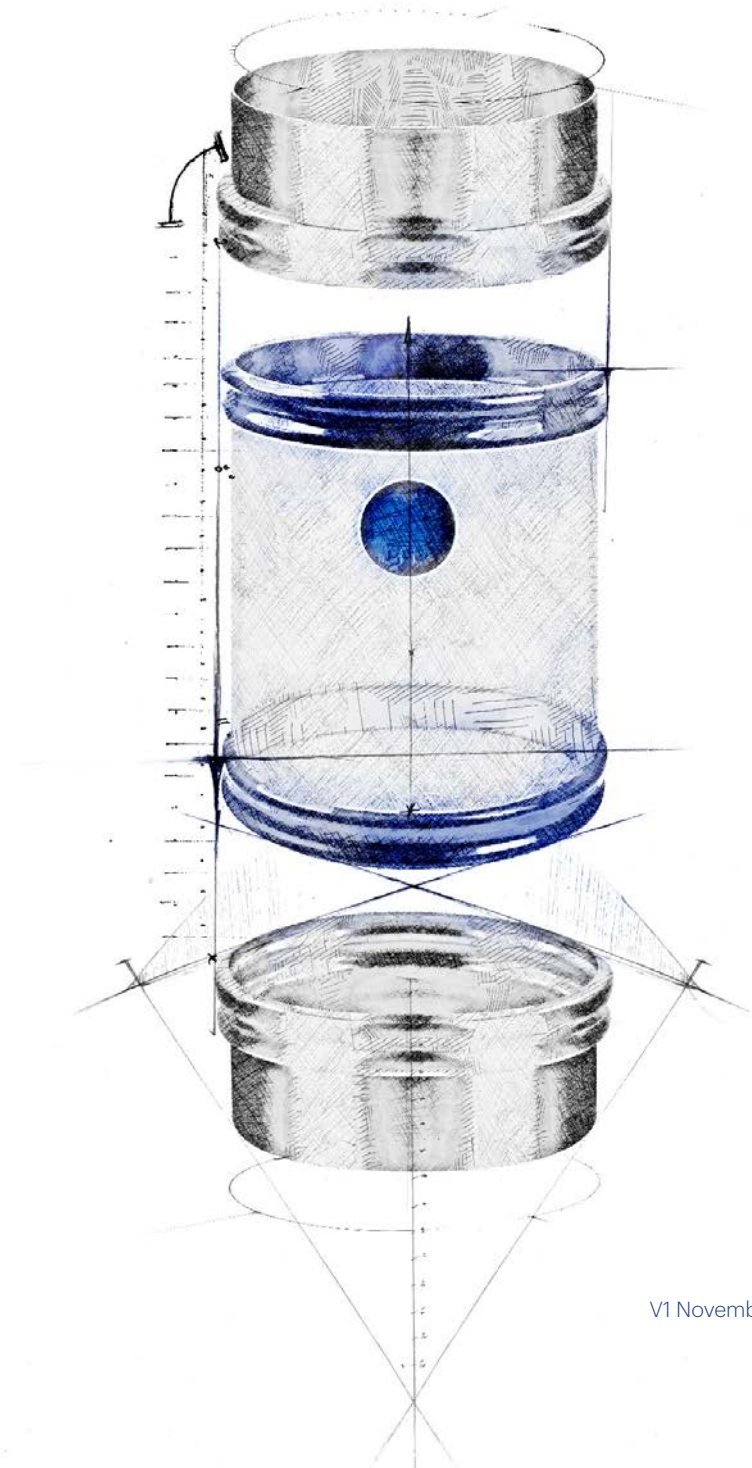

Installing a BFM[®] fitting Flexible Connector System

and other specialist BFM[®] products



Index

What is a BFM® fitting system?	1
Why install a BFM® fitting system?	2
Who uses BFM® fitting?	2
Where can BFM® fittings be used?	3
BFM® System Sizing	4
Diameters (∅)	4
Lengths	5
Diameter vs Length: What restrictions are there?	5
BFM® Spigots	6
Cross-section of a standard BFM® fitting Spigot:	6
Standard Spigots	7
Lipped Spigots	7
Installation Gap (IG)	8
What is it and why is it so important?	8
What happens if the IG is incorrect?	9
Measuring Before Installing	10
Steps for Finding the Correct IG and Connector Length	10
Measuring Offsets & Movement	12
How to physically measure vertical and horizontal movement	12
What to measure for different types of installations	13
Calculating The Correct IG	14
Step by step guide to using the BFM® IG Calculator	14
Additional tips for using the BFM® IG Calculator	15
Adjusting the IG for Vertical Movement	16
Adapting Spigots for Non-Metric Pipe Sizes	17
Adapting Pipework for Installation	18
Correcting for offsets	18
Non-Circular Connections:	19
Limited space for installation?	19
Installing a BFM® fitting System Horizontally	20
BFM® fitting Installation Examples	20
Streamlining Your Inventory	21
Improving efficiency by standardizing with BFM®	21
Standardization example	22

Flow Correction Methods	23
Welding Your Spigots	24
Non-Direct-Welded Options	26
Modular piping systems: Use BFM® Lipped Spigots	26
Pre-welding spigots to flanges	26
Fitting Your Connectors	27
Snap-fitting & removing standard BFM® fitting Connectors:	27
Additional Safety Options	28
Adapting Spigots for Use with TR (Tool Release) Systems	30
Standard Tool Release: Drilling a TR hole	30
Smiley Face Tool Release: Pneumatic Punch Tool	30
Tips for Installation & Removal of Tool Release Connectors	31
Installing a TR Lock-Out Safety System	32
BFM® Pneumatic Monitoring System	33
Product Overview	33
Installation Guide	34
BFM® Bulk Bag Loader	35
Product overview	35
Installation Guide	36
BFM® Weighing Bellows	37
Product overview & installation guide	37
BFM® Corner Connector	38
Product overview	38
Dimensions for Ordering Guide	39
BFM® Venting Surge Hopper	40
Product overview	40
Installation examples & tips	41

This booklet is designed to give you the information you need to know before installing a BFM® fitting flexible connector system.

Of course, if you have any questions not covered here, don't hesitate to contact your local Authorized BFM® fitting Distributor - they're there to help you get the most out of your BFM® fitting system.

You can also contact us at: info@BFMfitting.com

What is a BFM® fitting System?

A BFM® fitting system comprises a unique snap-in, BLUEBAND™ flexible connector that sits between two specially formed steel spigots (adaptors), welded to an inlet and outlet in a process line.

The BFM® fitting connector is distinct from all other flexible connectors in that it fits on the **inside** of the pipe, rather than being clamped to the outside.

The connector is 'snap-fitted' into specially shaped grooves in the spigot and the outward pressure of the metal 'snap' bands in the connector cuff hold it securely in place. The connector is simply snapped in and out manually in seconds.

No tools needed, no difficult screws or clamps and it's always fitted in exactly the correct place and is the right length every time.



Why install a BFM® fitting system?



VS



There are many benefits of installing a BFM® fitting system, and these provide significant long-term savings to your business that will far outweigh the initial purchase and installation cost.

- ✗ Powder leaks through clamps
- ✗ Overpressure causes high-risk clamp failure
- ✗ Difficult to fit, variations & inaccuracies
- ✗ Frequent downtime for replacements, clean-ups

- ✓ 100% sealed, no dust leaks, better hygiene
- ✓ Stronger pressure resistance & reduced explosion risk
- ✓ Easy snap-in system, consistent fit every time
- ✓ Longer lasting materials, quicker changes, less downtime

Who uses BFM® fittings?

BFM® fittings are the trusted flexible connector for major global manufacturers in the food, chemical, pharmaceutical and mineral industries around the world, including:



Where can BFM® fittings be used?

BFM® fitting can be used in multiple applications and conditions. They are most commonly found transporting bulk powder from one part of a process to another, often connecting stationary elements to moving equipment, such as sieves, sifters, tumblers and classifiers.



Ideal for transporting bulk products between different process areas.



Our Seeflex range offers a 100% seal, suitable for both positive and negative pressure applications.



Used in processing a variety of materials, from roasted coffee beans, to carbon black, to blood plasma.



BLUEBAND™ connectors can be used through metal detectors, at the base of hoppers, and where access to or visibility-of product flow is needed.



Excellent for transitions between stationary and moving equipment (e.g., sifters, sieves, vibratory tubes).

BFM[®] System Sizing

Understanding how a BFM[®] fitting system is measured and what sizes are available.

The standard BFM[®] fitting system comprises two steel spigot pipe adaptors and a connector of corresponding diameter.

- BFM[®]'s products are manufactured in metric sizes (any imperial measurements are approximate).
- All standard spigot sizes can be trimmed to fit imperial equivalents.

- Standardization of sizes across equipment is encouraged for easier maintenance.
- We recommend using connectors slightly larger than the pipe diameter to reduce abrasion on connectors.

- Our products have set diameters and lengths for consistent fit and simplified inventory.
- Opt for shortest possible connector length for efficiency and stock control.

Diameters (Ø)



- BFM[®] spigot adaptors are sized by 'ID' (Inside Diameter) at the tail (except for Ø100mm measured OD (Outside Diameter)).
- It's easy to adapt the standard spigot tail or pipework if the diameters don't match exactly.

- Sizes are based on metric measurements in 50mm increments starting at Ø100mm (plus a Ø125mm option).
- The BFM[®] fitting connector nominal diameters correspond to our spigot sizes.

- The spigot tail is about 5mm larger at the ridged head due to its tapered design.
- By default, connectors have identical diameters on both ends; tapered options are available for varying diameters (within specified parameters).

BFM[®] fitting spigots and connectors are available in the following diameters:



NOTE: There are some limitations on diameters for certain materials for connectors and if there are support rings inserted.



Download our QuickRef. Limitations Guide

Spigot Height (Length)

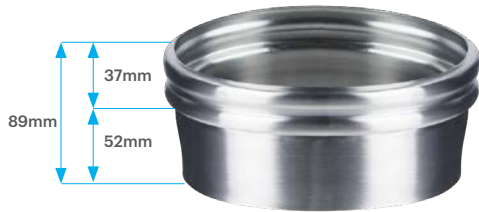

- **Standard Spigot Height:**
89mm (3 1/2") total
(‘head’ of 37mm (1 1/2") & ‘tail’ of 52mm (2"))
- **Lipped Spigot Height:**
83mm (3 11/64") total
(head of 37mm (1 29/64") & ‘tail’ of 46mm (1 13/16"))



Connector Length



- **Connector length** is measured to the inside of blue band cuffs (excluding the snap-band/cuff at ends).
- Standard lengths available:
 - Minimum of 80mm (3")
 - Increments of 50mm (2") from 100mm (4") up to 6 metres (19ft 8")*
- The minimum 80mm length is needed to allow space for manipulating the cuffs during insertion and removal.
- Extra length may be necessary for movement to ensure optimal performance.
- Refer to page 12 for detailed guidance on selecting the correct connector length and appropriate Installation Gap, especially for applications involving movement.

***NOTE:** some materials have restricted length availability, and for larger diameters from Ø700mm (27 1/2") upwards, length restrictions apply.

Diameter vs Length: What restrictions are there?

The largest connector diameter is Ø1,650mm (65"), and the corresponding lengths are subject to the following:

- **Ø700mm (27 1/2") ≤ Ø1,000mm (39 1/2")**
can have a maximum length of 500mm (20").
- **Ø1,050mm (41") ≤ Ø1,650mm (65")**
can have a maximum length of 200mm (8").

Additional diameter/length restrictions apply to different materials and for connectors with rings - the calculations are provided based on our most common Seeflex 040E material. Refer to the ‘Quick Ref Limitations Guide’ document for more information on the other material restrictions that apply.



Download our QuickRef.
Limitations Guide

BFM[®] Spigots

Understanding the anatomy of the BFM[®] precision-formed steel adaptors.

BFM[®] spigots are precision-formed steel adaptors that are welded onto an inlet and outlet in a process line to enable a snap-fit BFM[®] fitting flexible connector to be installed between them.

- A BFM[®] spigot has two ridges in the top ('head') matching the BFM[®] fitting connector cuffs. These ridges **CANNOT** be cut or adjusted as the connector fit will be compromised.
- The base or 'tail' has a slightly tapered shape – a standard spigot tail can be cut for welding to pipework if the space available or diameter needs some adjustment to fit.
- Metric sizing is used; nominal diameter measurements for spigots and connectors are based on ID at bottom of spigot tail (except for Ø100mm – measured OD).

Cross-section Of A Standard BFM[®] fitting Spigot:

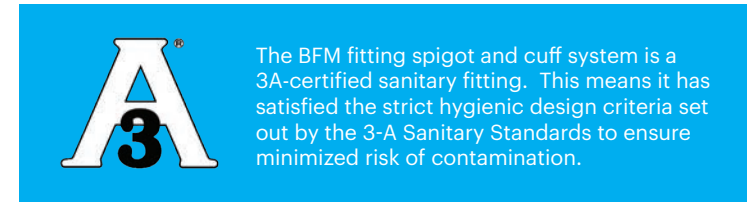
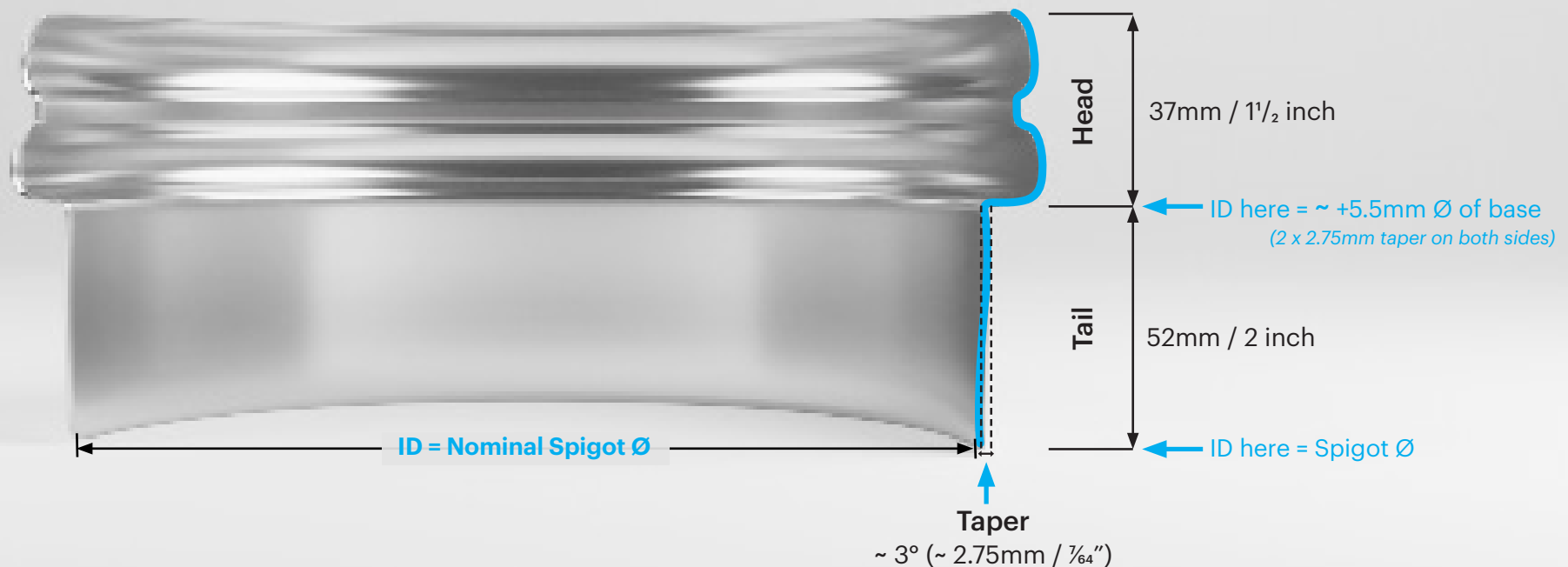

BFM® fitting Standard Spigots:



- Available in Stainless Steel T304L and T316L (C22 Hastelloy on request).
- Available in nominal diameters from Ø100mm through to Ø1,650mm in 50mm increments (including a Ø125mm diameter)
- Diameter is measured internally (ID) at the base of the tail, except for Ø100mm which is measured externally (OD). **Note:** There is a -1 / +3mm tolerance on the tail diameter of all spigot sizes.
- Wall thickness of steel for all diameters is 2.0mm / $\frac{5}{64}$ " (+/- 10%)
- The tail section is slightly tapered & can be easily cut down or cut on an angle to suit existing tubing or pipework.
- If cutting down, **extreme caution** must be used when welding to avoid any distortion of the shape of the spigot head.
- Surface finish is $\leq 0.8Ra$ micro-metres (32Ra micro-inches).

TIP:

Each spigot has a batch number and part number etched on the lower ridge - it is advisable for traceability not to remove this during finishing/polishing.

BFM® fitting Lipped Spigots:



- Available in Stainless Steel T304L
- Available in nominal diameters from Ø100mm through to Ø400mm only (in 50mm increments).
- 83mm ($3\frac{17}{64}$ "") in total length - made up of a head of 37mm ($1\frac{29}{64}$ "") and a 'tail' that is 46mm ($1\frac{13}{16}$ "") long.
- Lipped tail is compatible with most standard flanged, modular pipe systems
- The tail of a Lipped Spigot **cannot** be cut down.
- All other specs are as per standard BFM® spigots.

Did You Know?

We make .stp (step) files of our spigots (and connectors) available for download on our website so that you can easily integrate a BFM® fitting system into your system designs?



Go to our CAD Drawings page

Installation Gap (IG)

Why is it so important?

The initial installation process for a BFM® fitting system takes a little more preparation than most standard clamped systems – here's why:

Clamped Systems:

- 'Cut and fit' type clamped connectors allow rough estimation of length and cutting for installation – but the fit varies dependent on who installs it.
- Tight clamping can lead to tearing, premature wear, or product flow issues; loose fitting requires frequent adjustments causing production downtime.



BFM® fitting System:

- BFM® fitting system offers set-length connectors ensuring consistent snap-fit placement.
- Correct installation gap (IG) between BFM® spigot heads ensures optimal connector performance and long life.

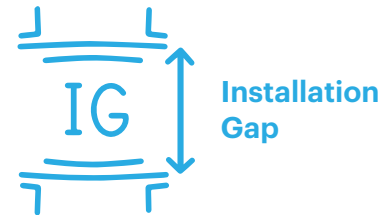

Watch our Installation Gap video

What determines the Installation Gap?

- IG calculation depends on several factors and these will affect 'X' (see the diagram on the page opposite).
- IG will always be slightly shorter than the connector length (CL).
- For stationary applications (with no offset) a simple calculation can be made by deducting 10mm off the connector length ('X' on the opposite diagram).
- A smaller IG is always needed for movement (vs stationary) to provide enough slack in the connector to allow for movement.

Always Use the BFM® IG Calculator!

- We recommend always using the IG calculator to ensure a correct Installation Gap.
- The BFM® Installation Gap Calculator is available as a downloadable app from the BFM® fitting website, Google Play, and Apple App Store.
- Spigot tails can be trimmed to accommodate limited space for achieving the correct Installation Gap.

(We recommend leaving at least 15mm ($\frac{19}{32}$ ") on the tail if possible for heat sink during welding).



Download the IG Calculator



Important measurements relating to installation Gap

- A** Length of the upper & **B** lower spigot; standard full length is 89mm (3 1/2") but tail may be shortened down if needed to a minimum of 37mm (1 2/64"). (A & B can be different lengths).
- X** Length to be deducted from the CL to ensure enough space to install and remove, and for sufficient flexibility of the connector (min. of 10 mm (25/64") for an 'in-line' installation with no movement). If the spigots are installed off-set, or if movement is involved, 'X' will always be more.
- CL** Connector Length - the length of the flexible, transparent part of the connector (between the cuffs). Standard lengths e.g. 100, 150, 200, 250 mm.
- IG** Installation Gap - the distance in between both spigot heads - always slightly smaller than CL.
- TS** Total space available between the two pipe ends that need to be connected.

IG (Installation Gap) is always slightly shorter than the CL (connector length)

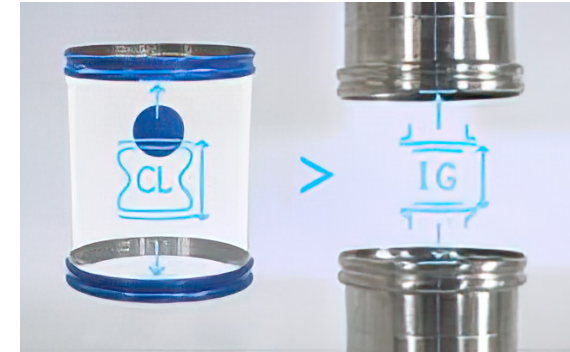

If you have VERTICAL MOVEMENT involved, refer to page 11 for more information on calculating for IG in this instance.

What happens if the IG is incorrect?



IG is Too Big

- Spigots positioned too far apart create an installation gap that is too big.
- This stretches connector, making installation and removal difficult.
- 100% seal may lose dust-tightness as cuff doesn't fit into spigot ridges correctly.
- Service life of connector compromised.



IG is Too Small

- Spigots positioned too close together result in an installation gap that is too small.
- Connector may have excessive creases and increased product contact.
- Material may rub on itself causing wear.
- Connector aperture may be reduced, restricting product flow.

NOTE: If there is movement or off-sets involved, the Installation Gap will need to be smaller than for a stationary application. Refer to page 12 for advice on Measuring for Movement, and always use the BFM® IG Calculator!

Measuring Before Installing

Steps for finding the correct Installation Gap and best connector length.



Watch Measuring for the Right BFM® Connector video

To get the maximum performance out of a BFM® fitting system, it's important to get the initial installation right - and it's a simple process of following some basic guidelines.

If you're going to be installing multiple connections, we recommend standardizing your flexible connector sizes wherever possible to make inventory control more streamlined and sustainable going forward.

Before installing your BFM® system spigots, check that you have gone over these steps to help ensure you get a perfect fit:

1 Identify Connection Type

Is the connection:

- Static inline
- Static offset*
- Vibrating
- Oscillating

This is important as an installation with movement or off-set requires a different IG and connector length to a static (stationary) in-line installation.



**We highly recommend that spigots are installed in-line rather than off-set if possible to avoid excessive wear on the connector.*

2 Find Total Space Available

- Measure the total possible space available between the two points to be connected.
- This should include anywhere you could cut your tubes/ pipes down to if necessary.
- Knowing how much space there is available for the installation is especially helpful if you are doing multiple installations and would like to try and standardize the size of your connectors.



3 Measure Diameters Ø

- Measure diameters on all connection points. If inlet & outlet connection points are different Ø, we recommend resizing pipework if possible so they are the same to simplify re-ordering. If not possible, tapered connectors are available.
- If installing multiple connectors, we recommend choosing a standardized connector size wherever possible and adapting your pipework to fit for simpler & faster connector re-ordering.



4 Identify Alignments Needed

- Plan to align any offsets/straighten any angles where possible to improve/extend the life of the BFM® connector.
- Where alignment isn't possible, due to space constraints for example, offset measurements should be taken.



5 Measure Offsets & Movement

- Measure any horizontal movement (or offsets that can't be straightened).
- For movement:
 - Perform the measurement at machine start-up and shutdown to record maximum movement (use slow-motion video).
 - Measure maximum movement/offset in one direction from a fixed point on one pipe.
 - A laser pointer can help with accurate measurements.



6 Calculate Best IG

- Once you have your measurements, use the BFM® IG Calculator to calculate the appropriate space to leave between your spigots (the IG) for specific connector lengths, based on your total space available (TS).
- You can adjust the spigot lengths and connector length in the slider to fit the total space available (TS) if needed.
- The IG Calculator is available on the BFM® website or via the Google Playstore or Apple App Store.



Measuring Offsets & Movement

Tips for measuring if you can't re-align pipes or if movement is involved.

Measuring 'offset' installations

- It's always recommended to install BFM® spigots to be in-line with each other in pipework.
- If alignment isn't possible, you will need to measure the horizontal offset between the pipes to be connected.



ABOVE: Realignment is the best option. If this is not possible, you will need to measure the off-set between the top & bottom pipes ('A' in illustration above) to be able to calculate the correct IG for your spigots.

How to physically measure horizontal movement:

There are several ways to measure movement depending on accessibility to the equipment.

For high-access equipment:

- Attach a laser pointer near the spigot position using magnets.



- Place a tape measure on the floor and record movement during start-up, operation, and shutdown.



For easier access locations:

- Use a vertical marker (stick or pole) at the edge of the moving pipe as a reference point.
- Hold a tape measure at right angles to the pole, extending across the front and past the pipe edge.
- Use slow-motion on a phone/camera positioned at the same height and 90° angle to the tape measure.
- Repeat measurements from multiple positions to capture uneven movement and maximum displacement.

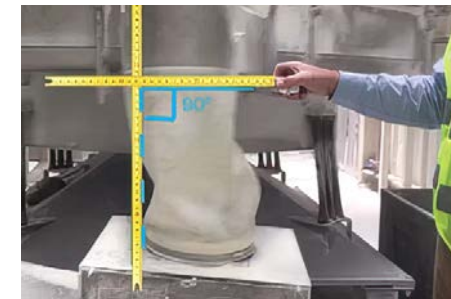

Vertical movement

For equipment with vertical movement (e.g., tumbler-type sifters):

- Measure and account for both vertical and horizontal movements.
- Significant movement typically occurs at start-up and shut down rather than during operation.
- Refer to page 16 for more information on adjusting the IG for Vertical Movement.

Download our
Calculating
IG for Vertical
Movement Guide



What to measure:



For Offset Static

The measurement to record is the horizontal difference between a fixed point on the top outlet/pipe compared to the same point on the bottom inlet/pipe.

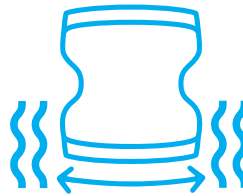

For Vibratory or Oscillating

The measurement to record is the maximum horizontal movement in either direction from a fixed point on the top pipe compared to the same point on the bottom pipe (where the spigots will be connected).

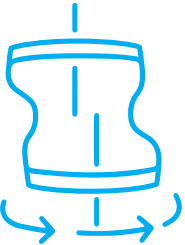

For Vibrating or Oscillating + Offset

The measurement is the maximum horizontal difference in either direction from a fixed point on the top pipe compared to the same point on the bottom pipe. This includes any initial offset (ie. you need to know the total maximum horizontal difference in either direction vs if the two pipes/connection points were in alignment).

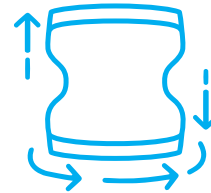

For Oscillation & Vertical Movement

You will need both the maximum horizontal and vertical movement (in either direction) from a fixed point on the top pipe compared to the same point on the bottom pipe/connection point.

Measuring Tips:

- You want to find the maximum movement in any one direction from a fixed point.
- It's usually easier to measure at the outside edge of the pipe/connection where the edge of the spigot will be.
- You must have the camera at the same height and take videos from multiple angles.
- Placing a piece of paper behind the moving pipe to give a plain background can help.
- For sieves and sifters, it is highly recommended to video the movement at both start-up and wind-down, as there is often a larger swing at this time than during regular operation.

Calculating The Correct IG



IG Calculator

Step by Step Guide to Using the BFM® IG Calculator

The BFM® Installation Gap Calculator allows you to calculate the correct Installation Gap and Minimum Space required to install a specific Connector Length.

Below is a step-by-step guide for using the IG Calculator for static (stationary), vibratory or oscillating machinery. If vertical movement is involved, an additional calculation adjustment is required – refer to the following pages for this and additional calculator tips and information.

1 Select 'Installation Type'
(You can adjust the 'Units' at any time during the calculation).

2 Enter the Pipe/ Connector Diameter

3 Enter the Desired Connector Length

4 Enter Any Off-Set or Movement

5 The Calculated Installation Gap

6 The Calculated Installation Gap

The screenshot shows the BFM fitting IG Calculator interface. On the left, there are buttons for 'Installation Type' (In-line Static, Offset Static, Vibratory, Oscillating, Oscillating Offset) and 'Units' (Millimetres, Inches). The 'Oscillating' option is selected. A central 3D model of a pipe and connector is shown with a ruler at the bottom. Annotations point to various fields: 'Diameter' (200mm), 'Total Spigot Length' (89mm), 'Connector Length' (400mm), 'Max Movement (one direction)' (20mm), 'Total Space Required' (562mm), and 'IG' (384mm). On the right, there are 'Save' buttons (Save 2 to Save 5) and a 'Save PDF' button. A text box at the bottom right explains that spigot lengths can be manually adjusted.

Installation Type: In-line Static, Offset Static, Vibratory, **Oscillating**, Oscillating Offset

Units: Millimetres, Inches

Key: CL - Connector Length, IG - Installation Gap

Not To Scale

Annotations:

- Step 1:** Points to the 'Installation Type' selection area.
- Step 2:** Points to the 'Diameter' field (200mm).
- Step 3:** Points to the 'Connector Length' field (400mm).
- Step 4:** Points to the 'Max Movement (one direction)' field (20mm).
- Step 5:** Points to the 'IG' field (384mm).
- Step 6:** Points to the 'Save PDF' button.

Right Panel Text:

Oscillate
400mm length
200mm diameter
20mm offset
89/89mm spigots

384mm IG
562mm Space

Save 2

Save 3

Save 4

Save 5

Save PDF

(You can also manually adjust the spigot lengths at any time).

Additional Tips for Using the BFM® IG Calculator

The BFM® IG Calculator only applies to diameters from Ø100mm to Ø650mm, and lengths from 100mm to 1,000mm. For any other sizes, please contact your local Authorized BFM® Distributor for assistance.



IG Calculator User Guide

Spigot Length:

- Top and bottom spigots can have different lengths.
- Default length for both is 89 mm (3.5"), adjustable down to minimum of 37 mm (1.29").
- Adjust one spigot to the max. first rather than a small amount on both.
- Spigots under 50 mm (2") need EXTREME CAUTION during welding to prevent distortion.

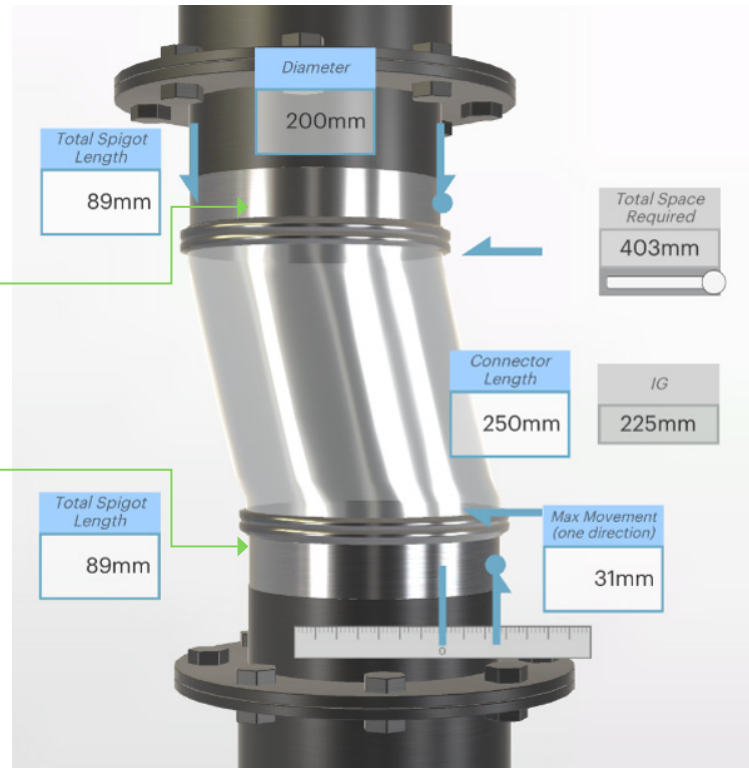

Saving Your Calculations:

- Press 'Enter' to confirm your last data entry in the Calculator.
- Click the 'Save 1' square on the right-hand side to save measurements for the calculation.
- Save up to 5 calculations simultaneously on screen.
- On mobile and desktop versions, export saved calculations as a PDF.
- For the online version, use screenshots (clipping tool or print-screen function) to save calculations.

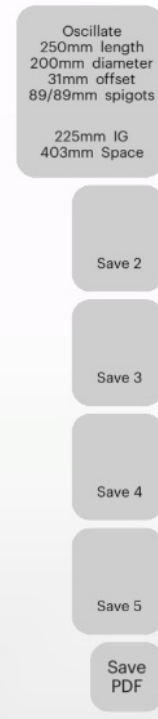

Using the sliders:

To get the sliders to appear you need to click into one of the editable boxes first e.g. Diameter, Spigot Length, Connector Length or Movement.

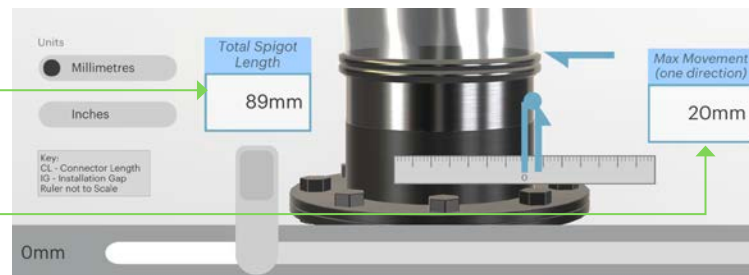

Maximum Allowable Offset/Movement:

To ensure optimal connector performance that apply to diameter vs length and the amount of movement or offset involved in any application:

Maximum Offset/Movement = 20% of CL (Connector Length) up to 100mm (max)

If this is exceeded, an alert will come up in the calculator.



TIP: For more information on general diameter & length restrictions for different materials, please refer to the 'Quick Reference Limitations Guide' on our website.

Adjusting the IG for Vertical Movement



Watch Adjusting IG for Vertical Movement video



Download Adjusting for Vertical Movement Guide

The IG provided by the BFM® IG Calculator only takes horizontal movement into account, therefore, if you also have vertical movement, you may need to make adjustments:

Step 1:

Find out the equipment position during shutdown (ie. The position it will be in when you weld on the spigots).

Step 2:

Adjust BFM® IG Calculator recommendations based on the following guidelines depending on the stopped position ie. maximum or another position.

Calculation Example This is based on the same example as the IG Calculator screen shot from the previous page.

IF MACHINE STOPS AT THE **MAXIMUM POSITION** OF THE VERTICAL MOVEMENT:

Install the spigots at the IG suggested by the calculator:

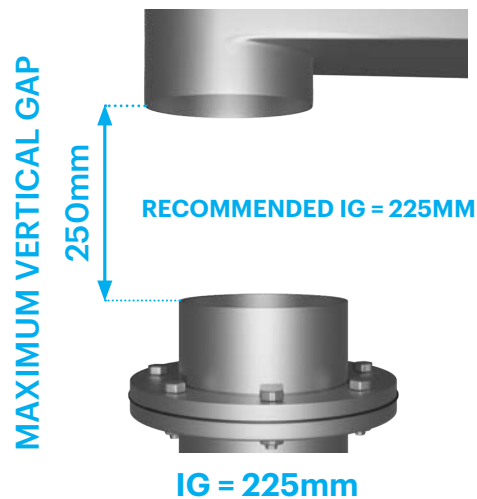

IF THE MACHINE STOPS AT **ANY OTHER POSITION**:

Subtract difference between the maximum vertical gap and the position the machine actually stops at from the suggested IG:

eg. $(250\text{mm} - 230\text{mm}) = 20\text{mm}$ difference

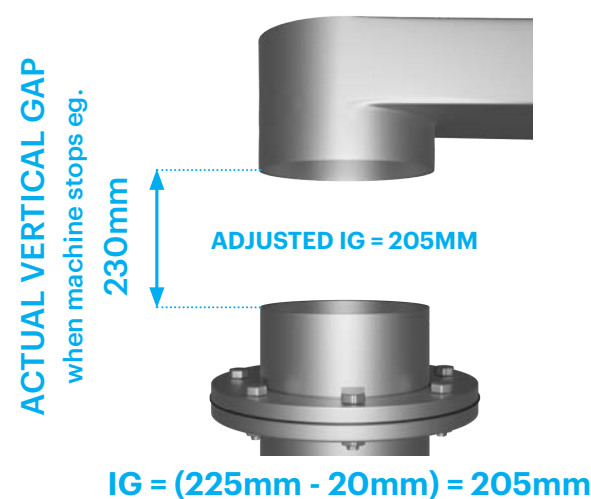

- The total available space for the installation is 500mm
- The maximum vertical gap at any point of the machine's operation is **250mm**
- The recommended Installation Gap based on the horizontal movement only (from the BFM® IG Calculator) was **225mm**
- The actual position the machine stops in has a vertical gap of **230mm**
- Maximum vertical position (250mm) less the position it actually stops at (230mm) gives a difference of **20mm**
- **Subtract the difference (20mm) from the recommended IG from the BFM® IG Calculator (225mm) to get the adjusted IG (205mm)**

NOTE: The above illustrations are not to scale and the total space you have available will determine whether you can cut your pipework or need to cut down the spigot tails to accommodate the recommended installation gap. (You can adjust the spigot tail length on the IG Calculator using the sliders - refer to pages 14 & 15).

Adapting Spigots for Non-Metric Pipe Sizes

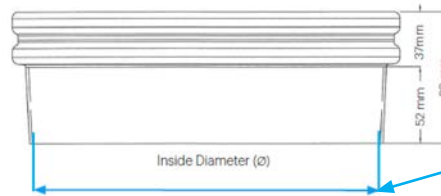

Ø 'Nominal' metric BFM® spigot diameter is measured here (for Ø ≥ 125mm)



Download Guide to Adjusting Spigots for Imperial Sizing

BFM® products are manufactured in metric sizes for compatibility with nominal bore standard pipe (internal measurement) so slight adjustments are needed for welding onto non-metric pipes (ie. Imperial, ANSI, JIS systems).

Metric vs Imperial /ANSI/JIS Sizes

The tables below indicate approximate equivalent sizes for non-metric pipe schedules and recommended adjustments for achieving equivalent Imperial pipe sizes by cutting or flaring/swaging the spigot tail.

BFM® Nominal Metric Ø	Nearest Imperial Size Ø	ANSI PIPE							JIS PIPE							
		PIPE	Pipe Schedule:				OD	PIPE	SIZE	Pipe Schedule:				OD		
100	4	4	6	8.6	11.1	13.5	17.1	114.3	100	4	5	6	7.1	8.6	13.5	114.3
125	5	5	6.6	9.5	12.7	15.9	19.1	141.3	125	5	5	6.6	8.1	9.5	15.9	139.8
150	6	6	7.1	11	14.3	18.2	21.9	168.3	150	6	6.5	7.1	9.3	11	18.2	165.2
200	8	8	8.2	12.7	25.4	23	22.2	219.1	200	8	6.5	8.2	10.3	12.7	23	216.3
250	10	10	9.3	12.7S 15.1C	-	28.6	-	273.1	250	10	6.5	9.3	12.7	15.1	28.6	267.4
300	12	12	9.55 10.3C	12.7S 17.5C	-	33.3	-	32.96	300	12	-	10.3	14.3	17.4	33.3	318.5
350	14	14	-	-	-	-	-	355.6	350	14	-	11.1	15.1	19	35.7	355.6
400	16	16	-	-	-	-	-	406.4	400	16	-	12.7	16.7	21.4	40.5	406.4
450	18	18	-	BENDING				457.2	450	18	-	14.3	19	23.8	45.2	457.2
500	20	20	-	-	-	-	-	508	500	20	-	15.1	20.6	26.2	50	508
550	22															
600	24	24	-	-	-	-	-	609.6	600	24	-	-	-	-	-	609.6

Adapting BFM® Spigots for use with Imperial Pipe Sizing

Use the following table as a guide to cutting down/flaring out your spigots to obtain an exact Imperial equivalent diameter. Take care to measure accurately and ensure the correct cut length!

BFM® Nominal Metric Ø	Nearest Imperial Size Ø	Amount to cut off the spigot tail to get exact imperial sizing (if pipe measured ID)	Amount to cut off/flare out the spigot tail to get exact Imperial sizing (if pipe measured OD)
(mm)	(inches)	mm	mm
100	4	37.6	13.1
125	5	16.3	Flare pipe/tube out 2.0mm
150	6	19.6	Flare pipe/tube out 1.6mm
200	8	26.2	Flare pipe/tube out 0.8mm
250	10	32.7	0
300	12	39.2	6.5
350	14	45.8	13.1
400	16	Flare pipe out 6.4mm	19.6
450	18	Flare pipe out 7.2mm	26.2
500	20	Flare pipe out 8.0mm	32.7
550	22	Flare pipe out 8.8mm	39.2
600	24	Flare pipe out 9.6mm	45.8

Adapting Pipework for Installation

Tips for preparing your pipes and equipment for installation of BFM® spigot adaptors

Correcting for Offsets

For optimal performance, we recommend aligning the inlet and outlet of flexible connectors vertically to minimize product contact with the connector walls.

- Product contact with connector walls during operation generates heat and abrasion. This can cause premature wear.
- Where possible, adapt steel piping to accommodate bends and ensure the connector is in straight pipe sections to minimize wall contact.
- Always use the Installation Gap Calculator, especially for installations with offsets or moving/oscillating equipment to determine correct installation gap for specific connector lengths.

Offset Guidelines

- The 'offset' is defined as the maximum pipe displacement in any direction from vertical alignment.



Offset installation is not recommended



Lower pipework re-aligned before spigot installed



BFM® installed "in line" by angling pipes/spigots at top and bottom

- The largest connector diameter recommended for offset applications is Ø500mm.
- For larger offsets than the IG Calculator allows, we recommend contacting your BFM® Authorized Distributor to discuss the best solution.

Non-Circular Connections:

Adapting to Circular BFM® Spigots

It's not unusual to see non-circular inlets or outlets that need to be connected, and there are many examples of simple pipe adaptations, like square to round flanges as shown adjacent:



Limited Space for Installation?

- BFM® spigot tails can be cut down to a minimum length of 37mm (1²⁹/₆₄”).
- For machinery connections that has access to inside the top of the equipment, it may be possible to effectively 'flush-mount' the spigot (from the inside) as shown adjacent.



IMPORTANT NOTE

For any spigot length under 50mm (2”), it is important to ensure you use a form of 'heat sink' when welding onto the pipe to avoid distorting the spigot shape.

The smallest space a BFM® fitting system can be installed into is 140mm (5 ³³/₆₄”)

This is based on an 80mm (3”) long connector in a static (non-moving) application, with both spigots cut down to the bare minimum of 37mm (1²⁹/₆₄”) each, and a 65mm (2¹/₂”) installation gap between the spigot heads.

Installing a BFM® fitting System Horizontally

A BFM® fitting system can be installed horizontally and the Installation Gap is calculated in the same way as vertical applications.

- The key issue to be aware of with horizontal installations is minimizing product-connector wall contact to avoid abrasion affecting connector lifespan.
- Rotate the connector regularly in horizontal installations to distribute wear evenly; use the blue brand stamp as a reference and keep rotation records in maintenance logs.

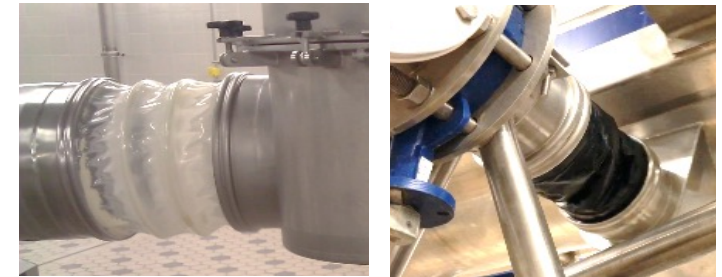

BFM® fitting Installation Examples

Our BLUEBAND™ connectors are installed in industries and applications as varied as lithium processing to infant formula production, chicken slurry transportation to waste plastic chip recycling.

They're used through metal detectors, on sifters, above rotary valves, in packing lines and at the bottom of silos, amongst other things.

Here are just a few examples of BFM® fittings installed in different applications around the world:



On a sifter processing paint pigment.



Raw chicken meat slurry under high vacuum.



Used through a metal detector checking cereals.



Double infeed for powders entering a tablet press.



Multiple BFM's on a sifter producing MSG.

Streamlining Your Inventory

Why standardizing connector sizes across your plant improves efficiency.

- Many manufacturers use various flexible connectors across their plants, differing in material, fitting style, quality, and safety conformity.
- Managing replacement stock and batch-tracking can be challenging due to the variety of connectors used.
- Switching to BFM® fitting connectors enhances hygiene and safety plant-wide.
- Standardized size range ensures accurate fitment every time, regardless of who changes a connector.
- Transitioning to BFM® fittings improves stock sustainability and efficiency in equipment transitions.

Common Problem with Old-Style Connectors:

- Multiple connection sizes, materials, fitting styles, and safety standards complicate maintenance and stock control.
- Spares must be stocked for each size, increasing inventory management complexity.
- Finding specific connectors quickly during failures is challenging often causing additional downtime.

BFM® Streamlined Solution:

- By rationalizing connector sizes from multiples down to just a handful of sizes, BFM® streamlines inventory control and improves supply chain sustainability.
- Exact sizes ensure a perfect fit every time with less downtime for installation and adjustments.



5 Reasons to standardize connectors to BFM®

Standardization Example

By adjusting pipe diameters to match and altering spigot tail lengths to ensure a correct installation gap (IG) for each position (depending on offset or movement involved) the connector sizes on this sifter have been consolidated from four down to one.



Watch Streamlining Your Inventory Video

Before BFM® - 4 different sizes

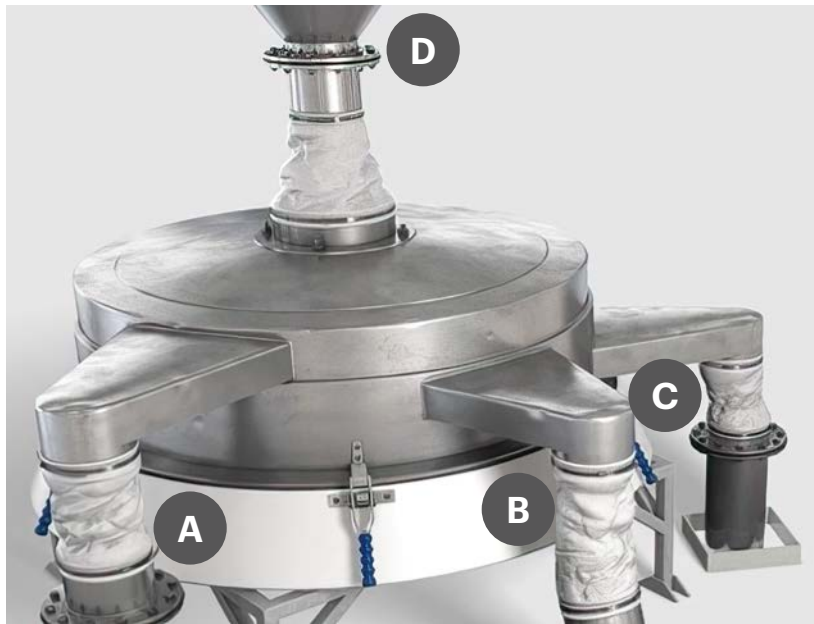

	A	B	C	D
Before BFM®				
Diameter (Ø) mm	252	246	250	250/305 (Taper)
Connector Length mm	310	380	330	315

After BFM® - 1 standard size

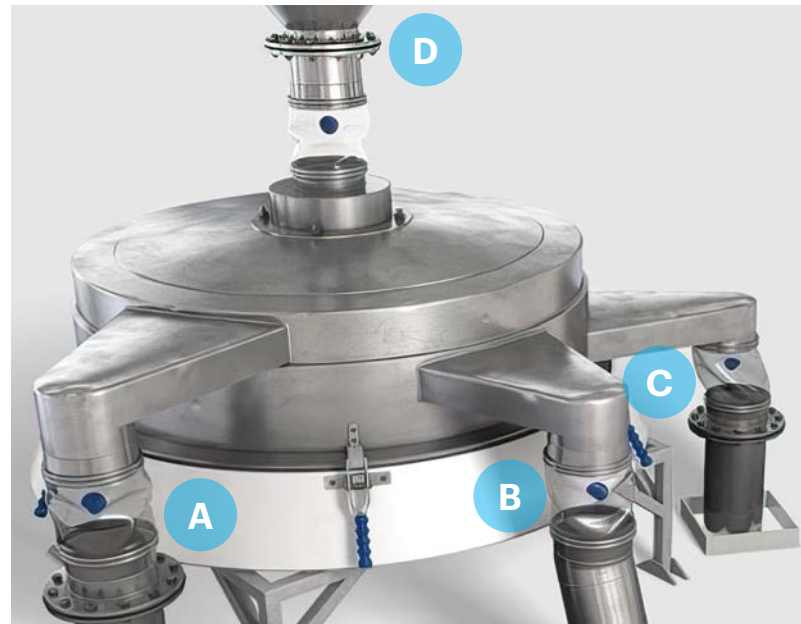

	A	B	C	D
After BFM®				
Diameter (Ø) mm	200	200	200	200
Connector Length mm	250	250	250	250

Flow Correction Methods

Extend the life of your flexible connectors by redirecting product flow.

Some powders can be highly aggressive when flowing through flexible connectors, causing excessive wear and tear

- We recommend using 'flow correction' methods like flow correction rings to redirect product flow and minimize wall contact.

- BFM® fitting system offers various options for integrating flow correction during installation, including selecting larger diameter connectors, using tapered connectors, or installing flow correction rings during spigot/pipe setup.

There are four standard methods of achieving flow correction with a BFM® fitting system

The ideal solution for flow correction depends on a number of factors, including connector length and diameter, the product being transported, flow rate and production/cleaning cycles.

Method 1

Use a Tapered connector with smaller diameter spigot at the top:

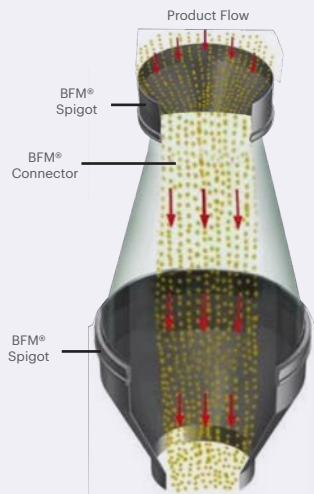

- Reduce the diameter of BFM® spigot at the inlet and increase the outlet diameter.
- Connect the outlet spigot to the pipe with a tapered steel transition.
- Ideal for **low-velocity** or **gravity-fed** product flows.

Method 2

Use a larger diameter BFM® spigot vs pipe at both top and bottom:

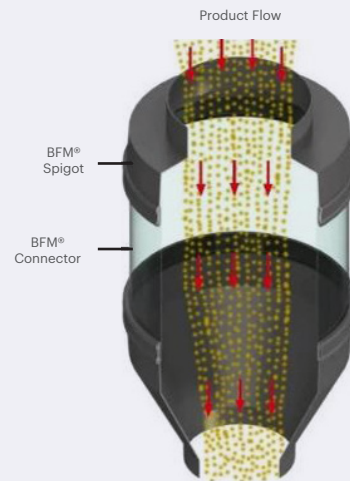

- Increase diameter of BFM® spigot at inlet larger than in-feed pipe diameter.
- Ensure product falls through without touching connector sides.
- Ideal for **low-velocity** or **gravity-fed** product flows.

Method 3

Use a flow ring that extends down inside the connector:

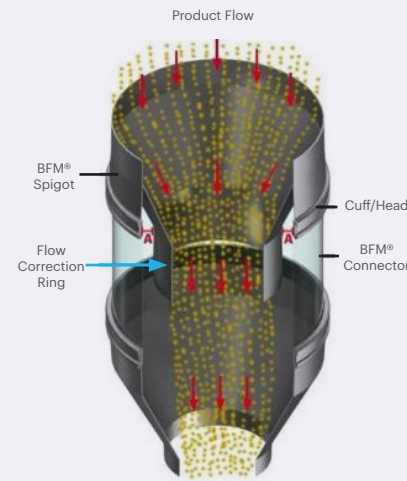

- Install a flow-correction ring that extends down past the connector cuff.
- Ensure the gap ('A' above) between flow correction ring & spigot cuff edge allows for easy connector replacement.
- Suitable for **low-velocity, high velocity** or **gravity-fed** product flows.

Method 4

Use a flow ring that finishes before spigot cuff/head:

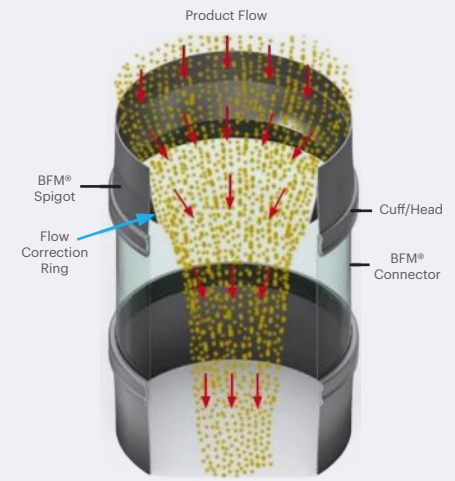

- Install a flow-correction ring inside the inlet BFM® spigot to direct powder flow inward away from connector walls.
- Suitable for any diameter spigot and does not affect connector replacement.
- Ideal for **low velocity, high-velocity** or **gravity-fed** flow applications.

Welding Your Spigots

Tips for physically installing your spigots

- Stainless steel spigots (flanges) have a 52mm (2") long tail.
- Spigots can be cut down or angled to fit existing pipework. Refer to installation instructions on previous page for details.
- Weld spigots considering flexible connector length and correct Installation Gap (IG) for the application.
- Use the BFM® Installation Gap Calculator App to calculate IG (visit www.bfmfitting.com/calculator).
- Ensure spigots are installed parallel to each other.
- Installing on an angle will impact connector performance.
- Re-align pipework if possible to ensure spigots are installed in-line with each other (offset installations are not recommended).
- Refer to page 18 for guidance on 'Aligning Offsets'.

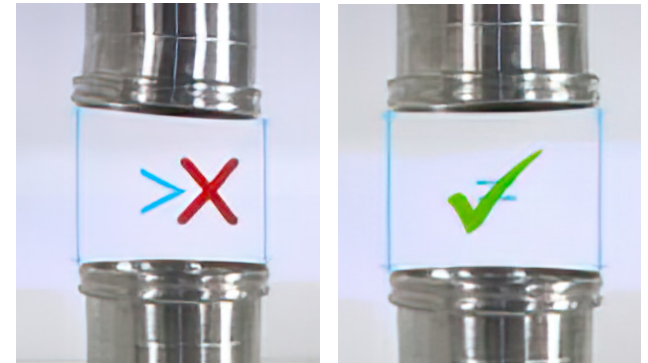

IMPORTANT:

Always ensure you know the correct Installation Gap (IG) **before welding the spigots** to your equipment (refer to pages 14-16 for more information)



1
Size spigot tail to pipe. The Pipe circumference may need to be expanded or reduced to suit the BFM® spigot. You can swage the spigot tail slightly if necessary.

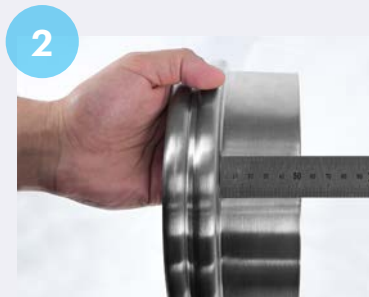

2
Avoid cutting the tail down if possible. If it is necessary to shorten it, we recommend leaving at least 15mm ($\frac{1}{2}$ ") on the tail for heat sink.



3
Tack BFM®spigot to correct sized pipe.



4
Peen the tacked joint to ensure correct fit.



5
Weld fitting on. Dress and polish to required standards

NEVER cut the BFM® spigot diameter

It is extremely important that the diameter of the spigot is never cut and do not attempt to re-size the head in any way.

This will affect the snap-fit of the connector cuff.



Take care to avoid heat shrinkage!

- Tail of the spigot can be cut to the base of the head. (although we recommend leaving at least 15mm ($19/32$ ") on the tail)
- Exercise extreme caution to prevent welding shrinkage as it can impact the fit of the flexible connector cuff.
- To prevent overheating large portions of the spigot, weld in small sections, e.g., 10mm at a time.
- Alternate welding around the connector circumference in thirds, eg:

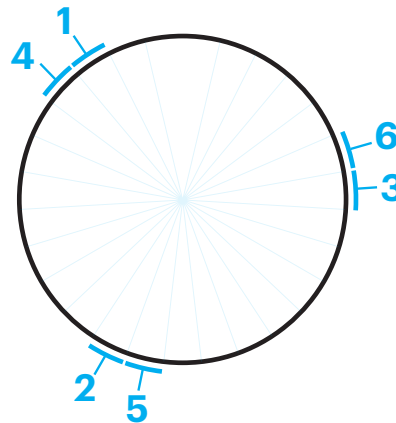

To ensure fitting tolerance of the connector.

All care must be taken to ensure that the circumference of the head after fitting and welding remains the same size as supplied.



Watch Spigot Welding
Guideline Video

Non-Direct-Welded Options

Ways of installing a BFM® fitting system without in-situ welding



Watch Lipped Spigot Overview Video

Whilst the most common method of installing a BFM® fitting system into a process line involves in-situ welding, there are other options.

Modular Piping Systems: Use BFM® Lipped Spigots

This is the fastest and easiest installation method and means you can have a BFM® fitting system installed in minutes.

- Most systems, like Jacob Tubing, use quick-release clamps with a standard 6mm 'lip' at the end of each pipe section.
- This 6mm 'lip' sits inside the clamp between a gasket and the next pipe section.
- BFM® 304L spigot adaptors are available with a 6mm rolled 'lip' (called a Lipped Spigot).
- Allows for instant clamping to an appropriate section of piping.



Pre-welding to Flanges

- Pre-welding a BFM® fitting spigot adaptor to a flange in the workshop allows easy installation before a shutdown.
- Eliminates the need for in-situ welding, speeding up the installation process.

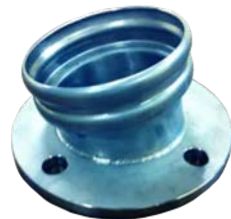

BFM® spigot welded to a flange

Connecting Spigot to a Flange

- Measure the flange ID (internal diameter) first & find the closest spigot diameter.
- Cut the spigot until its OD (outside diameter) matches the flange ID.

REMEMBER: BFM® Spigots have a 3-degree taper, approximately 5.5mm from bottom to top.

Our Distributors can assist in the process of adapting the spigots to your requirements if needed.

Benefits of the BFM® Lipped Spigot

- No welding required onto existing pipes
- Provides future flexibility in process line layout.
- Easier access for cleaning.
- Saves time and money on installation.
- Ideal for use with aluminium or plastic piping that can't be welded to steel spigots.



Installation Gap Is still Key!

- Proper planning is crucial for both direct-welded and non-direct-welded options.
- Ensure the appropriate Installation Gap (IG) is observed for optimal performance.
- Calculate the final positioning of the spigots to achieve maximum performance from the BFM® fitting connector.
- Refer to page 14-16 for details on the Installation Gap and calculation methods.

Fitting Your Connectors

Tips for installation & removal

Watch
Connector
Installation
Video:



Snap-fitting Standard BFM® fitting Connectors:



1
Ensure inside of the BFM® spigot is clean and dry.



2
Bend the BFM® connector into a kidney shape before placing it inside the BFM® spigot.



3
Align the back of the connector into the grooves of the spigot and release.

Removing Standard Connectors:



1
Apply pressure to the BFM® connector near the cuff until you are able to remove the connector cuff from the spigot.



2
Hold the cuff of the connector and remove it from the spigot.



Both top and bottom cuffs should be fully inside the corresponding spigot ridges – you shouldn't be able to see the blue bands.

DON'T



DON'T use pliers or similar to try and 'pull' the cuff into place as this may damage the connector material

DON'T push directly onto or next-to an indentation if the connector hasn't fully snapped out, as this won't help loosen the rest of the Seeflex sticking to the spigot.

If the connector doesn't snap in fully the first time:

Because of the incredible seal that forms with the Seeflex material and steel spigot, the cuff sometimes 'sticks' to the inside of the spigot ridges and doesn't snap-out fully the first time.



- To fix this, simply work around the cuff, pushing in with your thumbs to release the Seeflex until it 'snaps' fully into place.
- Start approximately 90° away from the first indentation and keep moving around the connector about 90° each time.
- Larger diameter connectors can sometimes take three or four pushes to release the Seeflex and snap the cuff in fully.

Additional Safety Options

Tool Release Systems



Watch Safety Options Video

To help protect worker's hands near dangerous moving parts like rotary valves or rotating knives, BFM® provides a range of additional safety options called 'Tool Release' or 'TR'.

- TR connectors have a much firmer 'snap-band' in their cuffs that make them virtually impossible to remove by hand.
- A specially shaped tool is required to release the connector, which is inserted through a similarly shaped hole in the spigot.
- This TR tool should be kept securely by a supervisor.
- To use the Tool Release connectors, the BFM® fitting spigot must have an appropriate TR hole in the top ridge.
- BFM® can provide spigots with a Tool Release hole or existing spigots can easily be retrofitted to be compatible with a Tool Release Connector.



- All BFM® connectors can be supplied as 'TR' Options (**NOTE:** The TR versions of our connectors have a different part number to the standard connector).
- Seeflex 040E/020E/ 060ES fittings have a white embossed identifier stamp for easy differentiation from standard fittings.
- Seeflex 040AS will have a Grey 040AS stamp but will also have 'Tool Release' imprinted on it.



DON'T install a TR connector in a spigot that does not have a TR hole in it as **it will be very difficult to remove!**

Standard Tool Release

- Any existing installation can be adapted to be able to use Tool Release (TR) connectors.
- Before installing a TR connector, a 6mm hole is drilled or punched in a standard BFM® spigot in the top ridge to allow insertion of the Tool Release tool.
- New spigots can be ordered with a TR hole already punched in them. See the following page for more information on drilling holes on existing spigots for use with TR connectors.



Smiley Face Tool Release

- For added safety, features a unique 'smiley' shaped hole in the edge of the spigot, preventing the use of tools other than the 'Smiley Face' Tool Release Tool.
- The Smiley Face Tool should be securely held and accessible only by authorized personnel to ensure safe operation.
- A Smiley Face Hole Punch Tool is available to retrofit existing spigots, or spigots can be ordered with a Smiley Face hole already punched.



TR Lock-Out Safety System

- Enhances safety by allowing a padlock to be inserted in front of the TR hole, preventing unauthorized connector removal.
- A 'TR Lock-Out' Tube is welded to the outside of the spigot over the TR hole in the top ridge of the BFM® fitting Spigot (see page 34)
- A padlock can be inserted through the holes in the top and bottom of the Lock-Out tube, blocking access to the TR hole.
- Only authorized staff with the key or combination to the padlock can access the TR hole to insert a Tool Release tool and remove the connector.



Adapting Spigots for Use with TR (Tool Release) Systems

Any size of BFM® Spigot can be supplied or adapted to be a TR spigot and this can be done in-situ.

BFM® fitting can also supply new spigots with either a standard or Smiley Face hole already drilled/punched.

NOTE: TR spigots have different part numbers to our standard spigots, so if you are ordering a pre-drilled/punched spigot, please ensure that you specify this with your Distributor.

Standard Tool Release: Drilling a TR Hole

A 6mm hole is drilled on the crest of the top ridge of a standard BFM® spigot in the position shown below (in both top and bottom spigots) to allow insertion of the Tool Release tool.

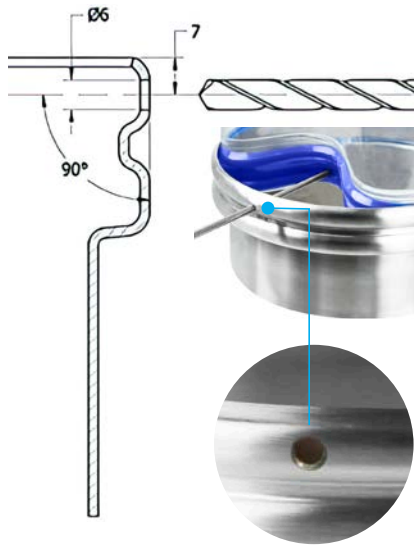

DO NOT drill a Tool Release hole in the valley of the two ridges on a BFM® Spigot!

This is a common mistake – the TR hole needs to be made **on the crest of the top ridge** as illustrated above.

Smiley Face Tool Release: Pneumatic Punch Tool

A Pneumatic Smiley Face Hole Punch tool has been developed to create the 'smiley face' holes in the spigot top ridge in exactly the right position

- The Smiley Face Hole Punch is clamped onto the edge of the BFM® spigot head
- A bolt is wound (using a ratchet) to punch a perfect 'smiley face' hole through the spigot ridge



Only the BFM® Smiley Face Tool can be inserted into this hole to release the cuff. The Smiley Face Hole Punch can be used on any diameter of BFM® fitting spigot.

Tips for Installation & Removal of Tool Release Connectors



Watch Installing & Removing TR Connectors

Installing Tool Release Connectors

- Ensure the spigot has a TR hole BEFORE installing a TR connector as it will be extremely difficult to remove once snapped into place!



Ensure the inside of the BFM® spigot is clean & dry.



Bend the BFM® connector into a kidney shape before placing it inside the BFM® spigot.



Align the back of the connector into the grooves of the spigot and release.



Snap into the second spigot, ensuring that the welded seam of the connector is straight and that points A and B are directly in line.

Removing Tool Release Connectors

- Removal is straightforward with a TR Release Tool that should be kept securely for authorized use only.



Insert the removal tool in the opening of the hole and push towards the centre of the fitting.



Hold the cuff of the connector and remove it from the spigot.

CAUTION!

To avoid injury, be sure to keep your thumbs/fingers clear of the cuff/seal when installing or removing TR connectors, as TR cuffs snap into place with considerable force.

PLEASE NOTE:

Although the firmer Tool Release snap band is a significant deterrent to manual removal, if an individual is determined enough, **it may still be possible.**

Important: Position Cuff Welds Away From The TR Tool Insertion Hole

- All Seeflex-range TR connectors are made so that the weld in the cuff is positioned on the **opposite side** to the embossed label on the front of the connector.
- To reduce the chance of the TR tool being inserted directly on the weld in the snap-band, always ensure you position the front embossed label directly above the TR insertion hole on the spigot.



Always have embossed label inserted directly above the TR insertion hole in spigot.

Installing a TR Lock-Out Safety System



Watch TR Lock-Out Safety System Overview Video

- The TR Lock-Out Safety System provides an additional layer of safety and can be applied to either the standard or Smiley Face TR system.
- It provides the ability to allow a padlock to be inserted over the Tool Release hole to prevent any unauthorised access to remove the Tool Release connector.
- Once the TR hole has been made in the top ridge of the spigot, the TR Lock-Out Safety Tube is welded over the top of the hole with the holes in the Tube facing up and down (and with the holes for the lock to go through positioned farthest away from the spigot).



PLEASE NOTE:

Extreme care must be taken when welding a TR Lock-Out Tube onto the Spigot to ensure no distortion of the top ridge of the Spigot occurs as this can affect the fit and seal of the BFM® fitting Connector.

We recommend the use of a heat-sink on the inside of the Spigot ridge during welding.

If the installation does not have strict hygiene requirements, you could simply tack-weld.

TR Lock-Out Tube

The TR Lock-Out Tube itself is an elliptical tubing made from 316 stainless steel with a 7mm hole through both top and bottom. It is pre-shaped to fit over the spigot ridge.



BFM® Pneumatic Monitoring System

Overview

- Designed for use in conjunction with BFM®'s Seeflex range of connectors.
- Provides ultimate connector safety by alerting if a connector is removed or not inserted correctly.

Installation and Usage

- Often installed above dangerous machinery, such as rotating knives or rotary valves, to protect staff.
- Pressurized air is pumped between the flexible cuff of the BFM® connector and the spigot.
- Air-line sensors (pressure switches) detect any loss of outward pressure as the connector cuff is pushed inwards.
- This can trigger an alarm and/or shut-off moving parts below if pressure is released.
- Invaluable for larger plants with multiple installations to ensure all connectors are in-place before start-up.
- Allows instant visibility from the control room to ensure all connectors are sealed properly before restarting production after stoppages.
- Available in two different versions: IP65-compliant or ATEX-compliant

The diagram below shows an overview of the basic set up for the BFM® Pneumatic Monitoring System, and a comprehensive guide to the installation process is on the following page.

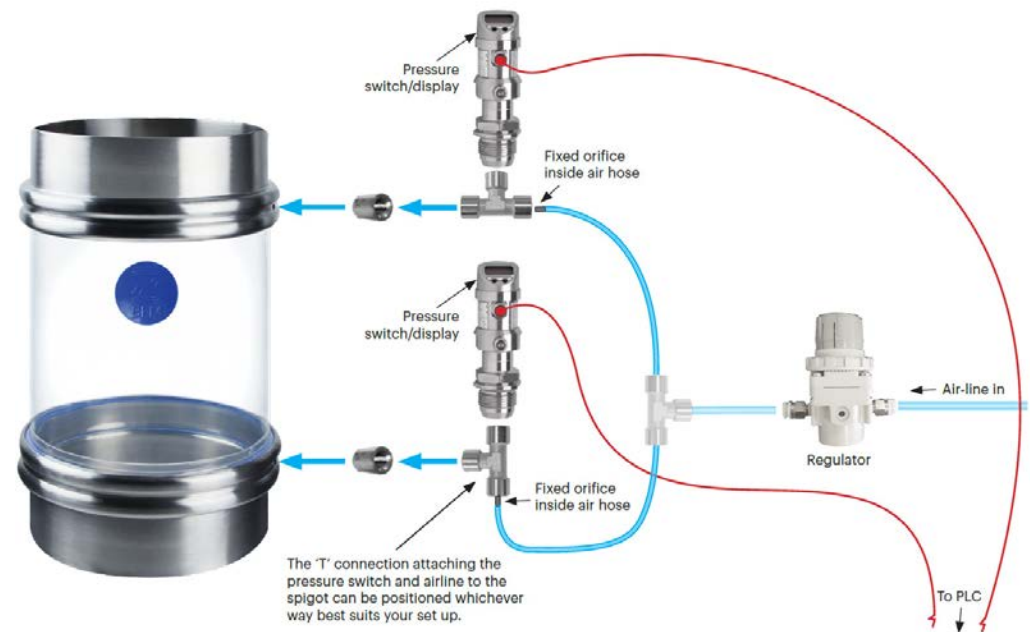

The BFM® Pneumatic monitoring system is available in IP65 or ATEX compliant versions. The diagrams on this page show the ATEX compliant Pressure Switch whilst the installation instructions on the following page show the IP65 Pressure Switch.

The process for installing both systems are exactly the same.

Installing a BFM® Pneumatic Monitoring System

- 1m of air-hose and approximately 1.9m of wiring is provided with the system.
- Additional air-hose, wiring and central T-junction connector are not included.

Installing System On Spigot



1 Weld the socket provided between the ridges of the BFM® spigot, ensuring the weld is clean.



2 Drill a 3mm (1/8") diameter hole in between the spigot's ridges through the weld socket.



3 Wind the T-fitting and pressure switch onto the socket so that it sits as shown.



4 Ensure the flow direction arrow on the regulator is towards the spigot side.



5 Connect the air hose to the T-fitting. Make sure the end containing the fixed orifice is placed into the T-fitting.



6 Connect the regulator to the air hose. Ensure regulator is closed and connect to the air supply.

CAUTION!

Extreme care must be taken not to distort spigot shape.

IMPORTANT

If you are also using TR (Tool Release) connectors, the hole being drilled for installing the Pneumatic Monitoring System should be located as far away as possible from the TR Tool hole to ensure there is no air leakage close to the sensor.

Setting The System

Ensure a BFM® Seeflex connector is fitted properly into the spigot during the setting process.



1 Zero the pressure switch.



2 Open the regulator and slowly increase pressure until reading on the pressure switch is approximately 30kPa or 4.35PSI.



3 Lock the regulator to this position avoid tampering by pushing down on top knob.



4 Follow the instructions leaflet included with the kit to set the window for the switching function. The upper limit should be adjusted to 40kPa or 5.8PSI*, and the lower limit to 20kPa or 2.9PSI.

The diagrams on this page show the IP65 compliant Pressure Switch, but the instructions for installing the ATEX system are the same.

*The upper pressure limit can be set higher if your product flow is pressurised or particularly dense and puts added pressure on the inside of the BFM® fitting.

These settings should be sensitive enough to detect removal or opening of the fitting from any point around the cuff, however:

- **Larger diameters** may require more than one pneumatic connection.
- For **TR connectors** you should ensure that the spigot weld socket for installing the Pneumatic Monitoring System is positioned as far away as it can be from the TR hole to reduce the possibility of air leakage close to the sensor.
- Additional weld sockets are available.

If you have any doubt, please contact your local BFM® Distributor for advice.

BFM® Bulk Bag Loader Overview

BFM® Bulk Bag Loader is a three-layered, inflatable filling head that combines the benefits of the BFM® snap fit with an inflatable outer bladder that seals perfectly.



- Features a stainless steel central core fully encased in BFM®'s strong, flexible Seeflex urethane.
- Snaps easily into a BFM® spigot welded to your outlet chute.
- Holds Bulk Bags securely during filling without dangerous clamps or bracing rings.
- Comes with a flexible, 160mm long air inlet tube with a plug-in airline fitting and built-in pressure relief valve.
- Once inflated, the superior seal ensures the neck of the bulk bag is securely held open with no leaks during loading.
- Outer sleeve can be instantly deflated for easy bag removal after loading.

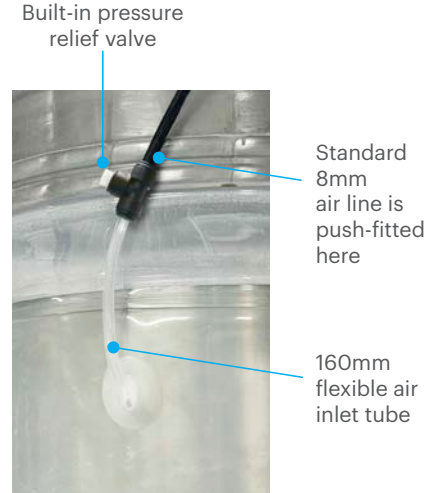

- Top of Bulk Bag Loader features a BFM® fitting snap-fit cuff that sits into a spigot welded onto the loading chute
- Lower end has a fully encapsulated stainless-steel ring at the lower end.
- Steel core pipe sits 50mm down from the top cuff to enable the Loader to be snapped in and out for cleaning if required.
- T-shaped, push-fit air line connection includes a built-in pressure relief valve, set to release at 6psi to help avoid over-inflation.

Diameter:	Expands To Fit Bag Neck Sizes:	Part No:
Ø150MM	Ø165 - Ø200mm	305078
Ø200MM	Ø220 - Ø260mm	305075
Ø250MM	Ø270 - Ø340mm	304794
Ø300MM	Ø320 - Ø395mm	304793
Ø350MM	Ø370 - Ø460mm	304791
Ø400MM	Ø420 - Ø540mm	302363
Ø450MM	Ø470 - Ø590mm	304828

Things To Know Before Installing

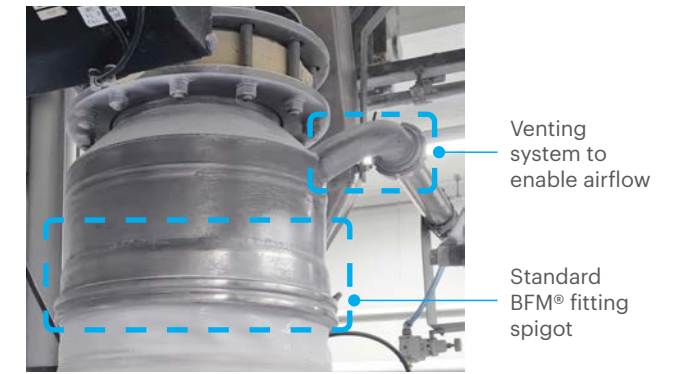

- Choose the appropriate sized Bulk Bag Loader diameter to fit your bags.
- You will need to have a BFM® Spigot of the appropriate size attached to your outlet pipe for the BFM® Bulk Bag Loader to snap into.
- A standard 8mm (OD) pneumatic air-line tube is required for operation.
- Recommended operating pressure is 3-4PSI (up to a maximum of 6PSI)
- A foot-controller for the air-line inlet valve is recommended, but not essential.
- Air-venting still needs to be enabled inside the filling chute.

BFM® Bulk Bag Loader: Installation Guide

STEP 1: Adapt the end of the existing outer pipe by welding on a BFM® spigot of the appropriate diameter.

STEP 2: Snap-fit the top (cuff) of the BFM® Bulk Bag Loader into the spigot as you would a standard BFM® fitting connector. (For more information on snap-fitting a BFM® fitting connector, refer to our Easy Installation Instructions document).

STEP 3: Run an 8mm (OD) air-line tube and connect it to the pneumatic air inlet T-shaped fitting.

STEP 4: Pull a bulk bag neck over the Bulk Bag Loader and open the air valve to inflate to find the appropriate expansion maximum for the bag neck diameter being used. Tug on the bag to ensure it is inflated enough to hold the bag neck securely then set the regulator.



Watch Bulk Bag Loader Demonstration Video



Watch BFM® vs Clamped Bulk Bag Loader video



NOTE: recommended operating pressure is 3 - 4 psi, but the maximum this should be set to is 6psi (0.41 Bar). The built-in pressure-relief valve is set to activate at 6psi. We strongly suggest using a precision regulator.



PLEASE NOTE:

If the central filling chute is going to extend downward (past the BFM® spigot towards the bottom of the Bulk Bag Loader), the diameter of the spigot & Bulk Bag Loader needs to be **at least 140mm larger** than the diameter of the central filling chute.

BFM® Weighing Bellows: Installation Guide



The BFM® Weighing Bellows is a precision connector designed to isolate sensitive weighing equipment from vibrations in the process line.

- Ideal for loss-in-weight feeders and equipment requiring high accuracy.
- Installation Gap (IG) of 80mm (3 5/32") between spigots for optimal performance.
- Spigots must be vertically aligned with no offset to ensure proper function.
- Universal Fit: The 80mm gap applies to all Weighing Bellows, regardless of diameter.

PLEASE NOTE:
Extreme care must be taken to account for shrinkage when welding to ensure that the spigot faces remain parallel and 80mm (3 5/32") apart.

Accurate IG of 80mm is Crucial when welding spigots for the Weighing Bellows Connector

1 Installation Gap (IG) must be 80mm (3 5/32")

Spigots for Weighing Bellows must be installed exactly 80mm (3 5/32") apart for optimum performance.

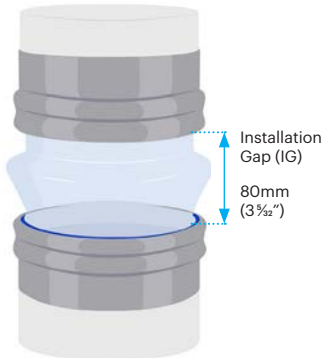

2 Use a 'spacer' for more accurate measurement when welding.

To aid with accurate installation, we recommend using a spacer, such as piece of 80mm (3 5/32") square tubing, cut to be at least 180mm (7") long.

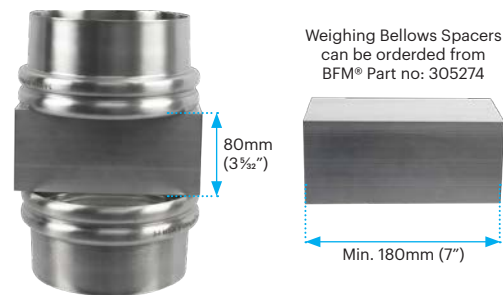

Once the bottom spigot has been welded on, simply sit the top spigot on the spacer when welding to the pipe/machinery above it to check that the correct Installation Gap is maintained throughout the welding process.

3 Ensure spigots are vertically aligned with no offset

For optimum performance of the Weighing Bellows connector, it is also extremely important to make sure that the top and bottom spigots are aligned vertically with no offset.



Remove Tensioner Ring before installing Weighing Bellows Connector

THE TENSIONER MUST BE REMOVED PRIOR TO USE!

All BFM® Weighing Bellows have a ring of light plastic tensioner tubing inside the formed position of the connector. We recommended that you keep this tensioner in when storing this product however, **this must be removed** prior to installation.

To safely remove the tensioner, please follow the next steps:



BFM[®] Corner Connector: Overview

The BFM[®] Corner Connector is a custom made connector that is designed to replace expensive steel, swivel-mounted tundish type set ups in many Clean In Place (CIP) processes. It can also be used in applications where product needs to be transported round a bend or under compact machinery with limited space.

- Made from our Seeflex O40E or O60ES material, usually with an infeed end that is tapered, a 110 bend and a straight drain output end.
- Can be made in diameter and drain length combinations to suit your installation requirements (subject to some manufacturing limitations)
- Snap-fits into standard BFM fitting spigots at each end to ensure a sealed drainage solution that is fast and easy to install and remove when required
- Simplifies CIP changeover processes and reduces the volume of expensive steelwork required.
- Also ideal for connecting sifter outlets to stationary process equipment directly without the need for steel piping (simply connect a spigot to both the sifter and the next process machine).



The BFM[®] Corner Connector replaces expensive steel swivel tundish type setups like this.



BFM[®] Venting Surge Hopper: Overview

The BFM[®] Venting Surge Hopper is an advanced intermediary hopper made from our durable and flexible Seeflex O40E material.

- Flexible walls provide a superior alternative to stainless-steel hoppers, especially for 'sticky' products prone to bridging. Easy to massage to free up product flow.
- Ideal for applications with pressure differentials, e.g. above rotary valves & bulk bag loading heads to ensure even product flow and effective air evacuation
- Features a central partition for separating product flow and air flow.
- Compatible with iris valves or slide-gates.
- Snap-fit design enables quick and easy cleaning, ideal for frequent product change-overs.
- Seeflex O40E material allows visibility of product flow, helping detect build-ups without risking product leakage
- Available in various diameters and lengths according to your requirements*



BFM[®] Venting Surge Hopper Spigot

- Custom made spigot that has a weir plate matching the connector partition angle.
- Materials: Stainless Steel T304L or T316L; custom-made with 4mm outer flange (DIN or ANSI) and internally welded weir.
- Adjustability: Tail and weir can be cut down or angled to match existing pipework.
- Weir Plate Specifications: 3mm thick, installed at a 6° angle, 50mm offset from centerline, extends 61mm above and 100mm below spigot body.
- Ordering Info: Specify flange standard (DIN or ANSI) for Venting Surge Hopper Spigot. Custom drawings are available upon request if you want to adapt your own BFM[®] spigot.
- Available Sizes: Ø200mm (8"), Ø250mm (10"), Ø300mm (12"), Ø350mm (14").

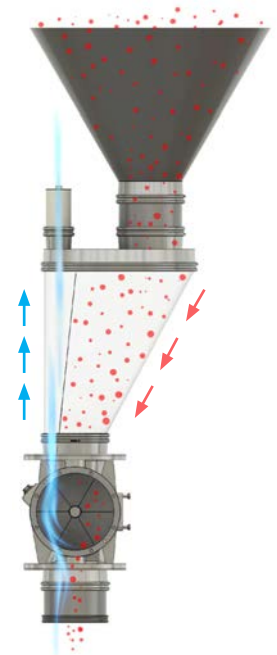
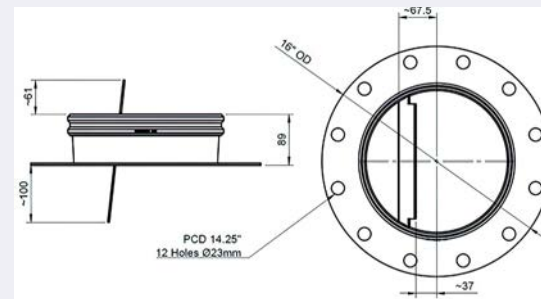

Watch Venting Surge Hopper Overview video

BFM[®] Venting Surge Hopper: Installation Examples

The BFM[®] Venting Surge Hopper is ideal for use in applications where product inflow needs to be regulated to ensure a consistent supply for the downstream process.

- Installation requires a custom BFM[®] Venting Surge Hopper Spigot on the lower end and standard BFM[®] spigot on the infeed end.
- The standard BFM[®] infeed (top) spigot transition typically needs to be adapted to allow product transfer and air removal – we recommend BFM[®] Seeflex connectors for the infeed, and FM1 Breather Bags to allow air-flow.

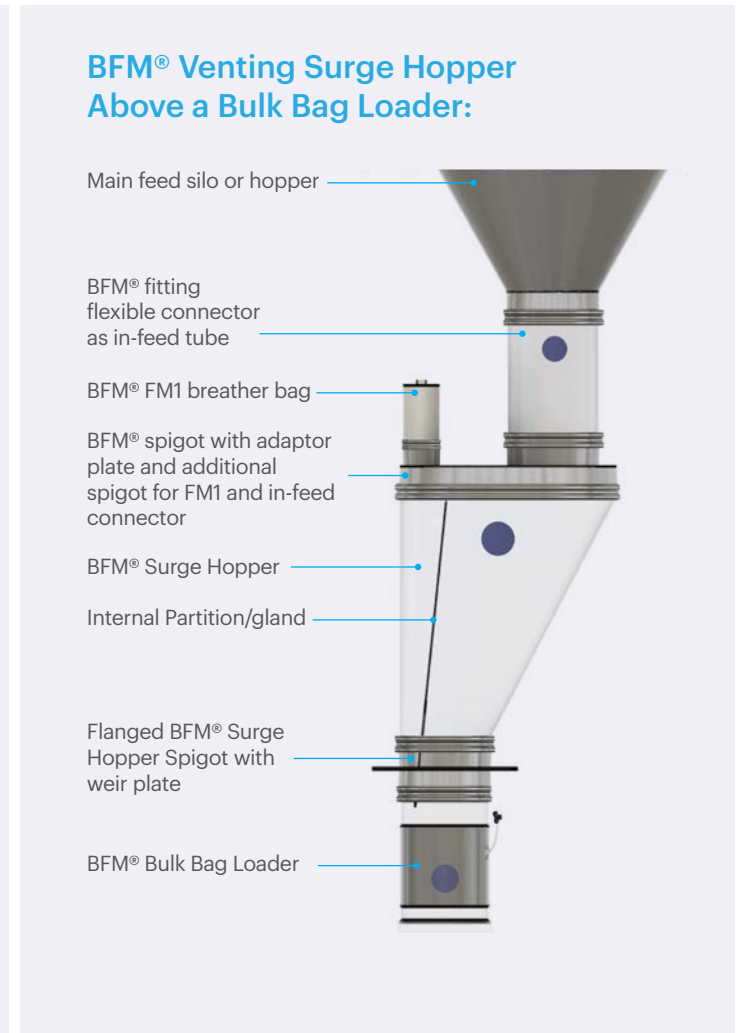
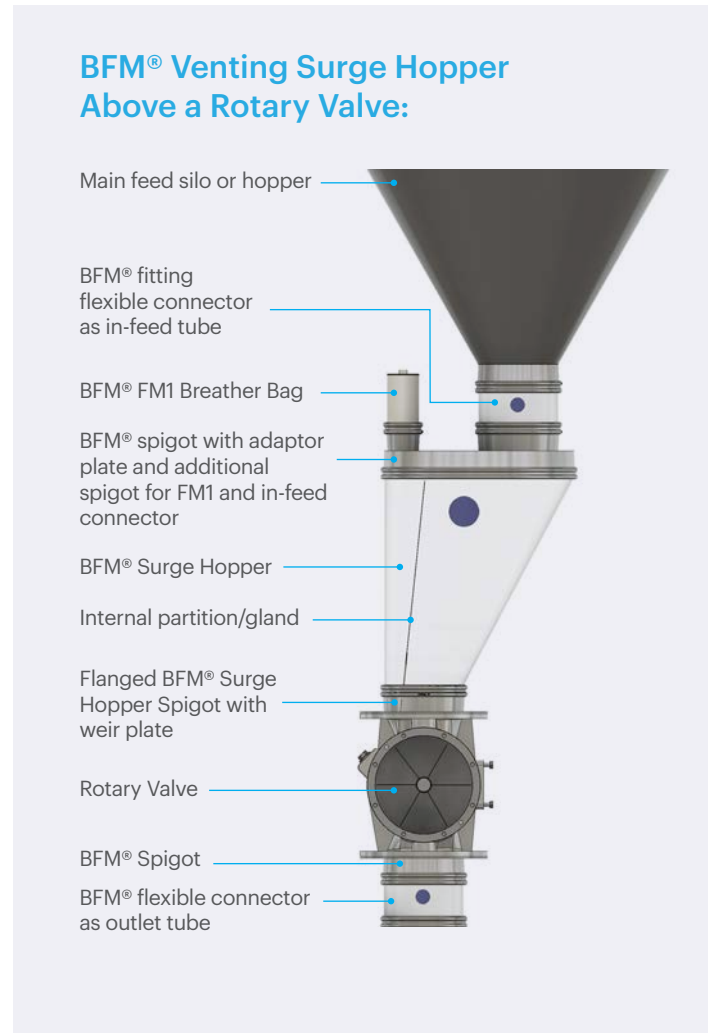

Installation Tips

- Installation Gap measurement should be 5mm less than the height (or 'length') of the Surge Hopper Connector ie: $IG = CL - 5mm$
- If your system isn't controlled by a levelling switch, consider installing a weir plate on the top spigot too to avoid overflow to the venting side. We can provide a drawing for this.
- Don't forget to add an FM1 Breather Bag to allow adequate air release!

Need more help?

Our products are supplied and supported around the world by over 50 experienced Authorized Distributors. They are there to help you select the right BFM® fitting connector for your application and can guide you through the installation process. You can find your local Authorized BFM® Distributor here <https://www.bfmfitting.com/distributors>



For more information go to: www.BFMfitting.com

Email us at: info@BFMfitting.com

