

# BFM® WEIGHING BELLOWS INSTALLATION

## WELDING YOUR SPIGOTS: Installation Gap & Alignment is Crucial

Before welding your spigots (or adaptors) on to your machinery for installing your Weighing Bellows, it is essential to ensure that the Installation Gap (or the gap between the spigots where the connector will sit) is exactly 80mm (3 $\frac{5}{32}$ " ) apart for optimum performance. The spigots must also be vertically aligned with no off-set.

This Installation Gap (IG) height applies to all Weighing Bellows, irrespective of diameter.

### 1. Installation gap (IG) must be 80mm (3 $\frac{5}{32}$ " )

Spigots for Weighing Bellows must be installed exactly 80mm (3 $\frac{5}{32}$ " ) apart for optimum performance.

### 2. Use a 'spacer' for more accurate measurement when welding

To aid with accurate installation, we recommended using a spacer, such as piece of 80mm (3 $\frac{5}{32}$ " ) square tubing, cut to be at least 180mm (7" ) long.

Once the bottom spigot has been welded on, simply sit the top spigot on the spacer when welding to the pipe/ machinery above it to ensure correct Installation Gap is maintained.

### 3. Ensure spigots are aligned with no off-set

For optimum performance of the Weighing Bellows connector, it is also extremely important to make sure that the top and bottom spigots are aligned vertically with no off-set.

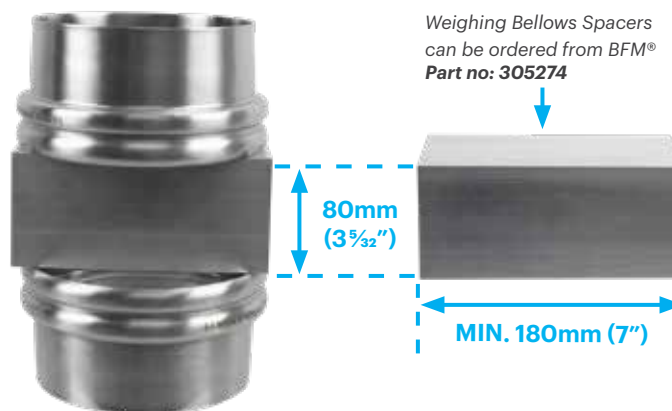
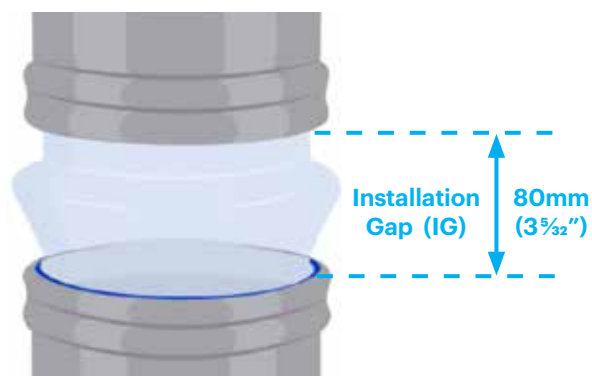

**NOTE:** Care must be taken when welding to account for shrinkage.

## BFM® Weighing Bellows Installation

**REMOVING TENSIONER RING**

When you receive the BFM® Weighing Bellows connector, you will notice that there is a black tensioner ring made from light plastic tubing inside the formed portion of the connector.

It is inserted to help support this formed portion of the Weighing Bellows during shipping and storage to help ensure it keeps the perfect shape prior to installation.

**IMPORTANT: THE TENSIONER MUST BE REMOVED PRIOR TO USE!**

All BFM® Weighing Bellows have a ring of light plastic tensioner tubing inside the formed position of the connector. We recommend that you keep this tensioner in when storing this product however, this must be removed prior to installation.

To safely remove the tensioner, please follow the steps below.

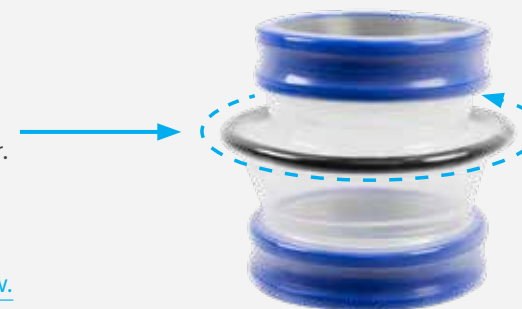
**TENSIONER REMOVAL:**

From the outside, apply force to push the tensioner ring inwards to release it from the formed portion of the connector.



Once released, grasp the tensioner ring with your fingers and pull the entire ring out of the connector completely.



You can now dispose of the black tensioner ring as it is no longer needed.

**Your BFM® Weighing Bellows is ready for installation!**